



GB5P

Spur Reduction Gearheads - 0.5 to 1Nm

Design

Gearhead GB5P, the most popular gearhead, is a multi step gear box with all polyacetal gears which rotate on steel spindles which are polished to a mirror-finish and introduced between metal plates with a plastic frame. All bearings are permanently lubricated and therefore require no maintenance. Motor is attached to the gear box by means of snap clip. Thicker shafts (Ø6-7mm) mounted in robust bushings (Ø12mm) are available (GB5PS). Similarly the gears at the output end can be metal with thick shafts & robust bushings. Sintered gears variant also possible GB5P can also be combined with small DC Motors. To achieve higher gear torque, GB5P can be mounted on GB4, GBW & GBX. In same mounting we can also offer casted gearhead with & without ball bearing.

Features

Gearhead GB5P, the most popular gearhead, is a multi step gear box with all polyacetal gears which rotate on steel spindles which are polished to a mirror-finish and introduced between metal plates with a plastic frame. All bearings are permanently lubricated and therefore require no maintenance. Motor is attached to the gear box by means of snap clip. Thicker shafts (Ø6-7mm) mounted in robust bushings (Ø12mm) are available (GB5PS). Similarly the gears at the output end can be metal with thick shafts & robust bushings. Sintered gears variant also possible GB5P can also be combined with small DC Motors. To achieve higher gear torque, GB5P can be mounted on GB4, GBW & GBX. In same mounting we can also offer casted gearhead with & without ball bearing.

Application

Instrumentation, diamond machinery, peristaltic pumps, motorised displays, programming devices, cam timers, medical equipment, valves and actuators.

Options

Gearhead GB5P, the most popular gearhead, is a multi step gear box with all polyacetal gears which rotate on steel spindles which are polished to a mirror-finish and introduced between metal plates with a plastic frame. All bearings are permanently lubricated and therefore require no maintenance. Motor is attached to the gear box by means of snap clip. Thicker shafts (Ø6-7mm) mounted in robust bushings (Ø12mm) are available (GB5PS). Similarly the gears at the output end can be metal with thick shafts & robust bushings. Sintered gears variant also possible GB5P can also be combined with small DC Motors. To achieve higher gear torque, GB5P can be mounted on GB4, GBW & GBX. In same mounting we can also offer casted gearhead with & without ball bearing.

Standard Data

Parameter	Value	Unit
Gear type	Spur (1st Pair helical for certain ratios)	
Gear Torque	0.5 to 1	
Combination with Mechtex motors	Motor MT0, MT6, MTR/S3a/3b, MTR/S4a/4b and small DC motors	
Mounting	any position	
Weight	60	g
Axial thrust	20	N
Lateral force	60	N
Radial torque	0.6	Nm
Slipping clutches/free wheel	available for certain ratios	
Output bearing	Sintered bronze sleeve bushings, (Ball bearing on request)	
Output shafts	3.175, 4.00, 4.76, 5.00, 6.00 & 7.00 (others on request)	Ø
Ambient temperature operation	-15...+ 55	°C
Enclosure	40	IP

Technical Data

Parameter	Value	Unit
Shaft type	OV	-
D (+0.00/-0.10)	8	
H	3.5	
d (dia)	4	
L	12.5	
I	9	
d	3.6	
I	20	
L	36	
R	3.6	
C	M4	
M		
h		
k		
P		
Q		

dimensional drawing

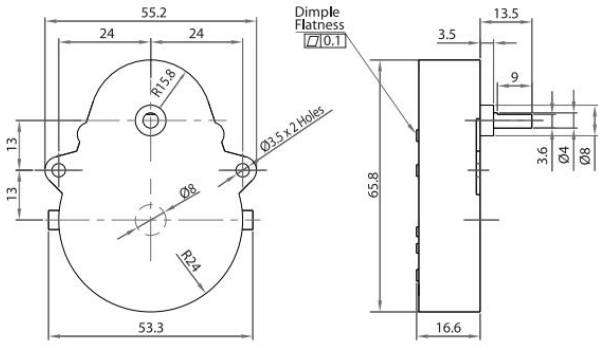

Shaft Drawing

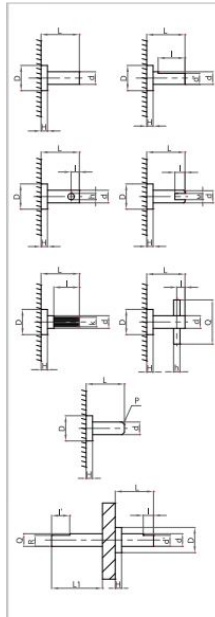

Assembly Drawings

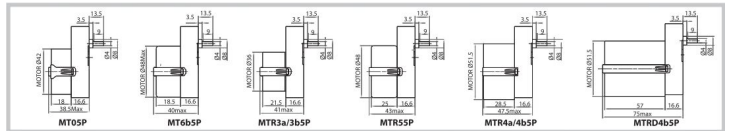

Life graph Transmission Ratios

