



## GBU



### Spur Reduction Gearheads -6Nm

#### Design

Gearhead GBU contains heavily loaded steel gear wheels. The spur gears are fixed on steel spindles which are hardened and polished to a mirror finish & rotate in robust sintered bushings. The thick output shaft rotates in robust sintered bronze bushings. All the gears are housed in between metal plates & closed by plastic dust cover. All bearings are permanently lubricated and therefore require no maintenance. GBU can also be combined with small to medium sizes of DC motors (up to 52mm).

#### Features

Gearhead GBU contains heavily loaded steel gear wheels. The spur gears are fixed on steel spindles which are hardened and polished to a mirror finish & rotate in robust sintered bushings. The thick output shaft rotates in robust sintered bronze bushings. All the gears are housed in between metal plates & closed by plastic dust cover. All bearings are permanently lubricated and therefore require no maintenance. GBU can also be combined with small to medium sizes of DC motors (up to 52mm).

#### Application

Timers, Chart Recorders, Potentiometer Drives, Light Displays, Hour Meters, Cam Timers, Programming Devices and Control Instrumentation.

#### Options

Gearhead GBU contains heavily loaded steel gear wheels. The spur gears are fixed on steel spindles which are hardened and polished to a mirror finish & rotate in robust sintered bushings. The thick output shaft rotates in robust sintered bronze bushings. All the gears are housed in between metal plates & closed by plastic dust cover. All bearings are permanently lubricated and therefore require no maintenance. GBU can also be combined with small to medium sizes of DC motors (up to 52mm).

#### Standard Data

Parameter	Value	Unit
Gear type	Spur Reduction	
Gear Torque	6	Nm
Combination with Mechtex motors	MT0,MT6,MTR/S5,MTR/S-4a/b,MTR/SD-4,MTR/SD4-RE & DC motors (up to 052mm) MTR/S 7a & MTR/S 8c	
Mounting	any position	
Weight	350	g
Axial thrust	30	N
Lateral force	250	N
Radial torque	4	Nm
Output bearing	Sintered bronze sleeve bushings. Ball Bearing (on special request)	
Output shafts	dia. 8 x 25 mm (with a flat), others on request	
Ambient temperature operation	-15...+ 55	°C
Enclosure	30	IP

#### Technical Data

Parameter	Value	Unit
Shaft type	OS	
D (+0.00/-0.10)	14	
H	3	
d (dia)	8	
L	25	
I	18	
d	6	
h		

**dimensional drawing**

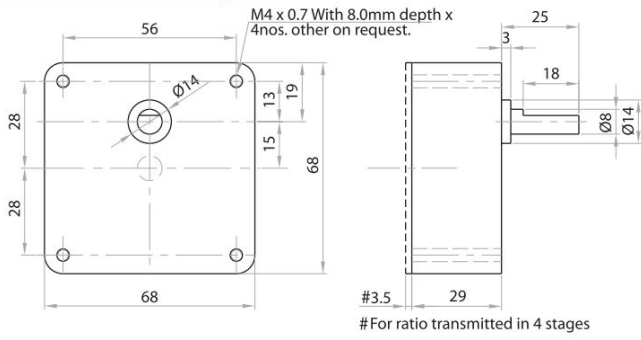

**Shaft Drawing**

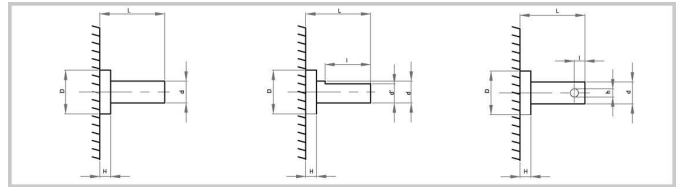

**Assembly Drawings**

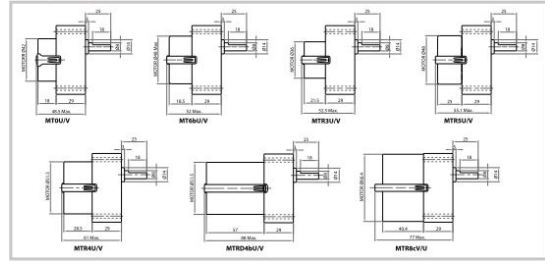

**Life graph Transmission Ratios**

